

# **Custom Light Measurement System Spectra Vista 3 Inch DC-R/T Sphere**

**Rev H  
January 2025**

**Labsphere, Inc. 231 Shaker Street, North Sutton, NH 03260 US  
[www.labsphere.com](http://www.labsphere.com) +1.603.927.4266**



**Spectra Vista Corporation, 29 Firemens Way, Poughkeepsie, NY 12603 USA  
[www.spectravista.com](http://www.spectravista.com) +1.845.471.7007**







## 1. TABLE OF CONTENTS

|      |   |    |
|------|---|----|
| 2.   | List of Figures / Tables .....                          | 4  |
| 3.   | Document Conventions.....                               | 5  |
| 4.   | Reserved.....   | 5  |
| 5.   | Unpacking The System.....                               | 6  |
| 5.1. | System Overview .....                                   | 7  |
| 6.   | Installing The Sphere On The SVC Spectroradiometer..... | 9  |
| 6.1. | Attaching The Sphere.....                               | 9  |
| 6.2. | Powering / Controlling The Sphere.....                  | 14 |
| 7.   | Lamp Placement.....                                     | 16 |
| 8.   | Reflectance measurements.....                           | 18 |
| 8.1. | Stray Light Measurement.....                            | 19 |
| 8.2. | Calibrated Standard Reflectance Measurement .....       | 20 |
| 8.3. | Sample Reflectance Measurement .....                    | 21 |
| 8.4. | Calculating Sample Spectral Reflectance .....           | 22 |
| 9.   | Transmittance Measurements .....                        | 23 |
| 9.1. | Sphere-Only Transmittance Measurement.....              | 24 |
| 9.2. | Sample Transmittance Measurement .....                  | 26 |
| 9.3. | Calculating Sample Spectral Transmittance .....         | 28 |
| 10.  | System Configuration When Not in Use .....              | 29 |
| 11.  | Lamp Bulb Replacement.....                              | 30 |
| 12.  | Lamp Beam Alignment Test.....                           | 32 |
| 13.  | Aligning Lamp Light Beam.....                           | 33 |
| 14.  | Appendix A: Reflectance / Transmission Quickstart.....  | 36 |

## 2. LIST OF FIGURES / TABLES

|  |    |
|--|----|
| Figure 1: System in its shipment container (configuration #1).....         | 6  |
| Figure 2: System in its shipment container (configuration #2).....         | 7  |
| Figure 3: System view .....  | 8  |
| Figure 4: Sphere mounted on spectroradiometer .....                        | 9  |
| Figure 5: SVC DC-R/T Sphere component parts .....                          | 10 |
| Figure 6: Installing the instrument support legs .....                     | 11 |
| Figure 7: Support bracket installed on the sphere assembly.....            | 12 |
| Figure 8: Preparing to attach the sphere to the spectroradiometer.....     | 12 |
| Figure 9: Sphere attached to spectroradiometer.....                        | 13 |
| Figure 10: Main power supply .....   | 14 |
| Figure 11: Sphere Power Module .....                                       | 14 |
| Figure 12: Sphere Intensity Controls .....                                 | 15 |
| Figure 13: Changing lamp position.....                                     | 17 |
| Figure 14: Stray light measurement configuration .....                     | 19 |
| Figure 15: Calibrated standard reflectance measurement configuration ..... | 20 |
| Figure 16: Sample reflectance measurement configuration.....               | 21 |
| Figure 17: Sphere-only transmittance measurement configuration .....       | 24 |
| Figure 18: Port plug correct orientation.....                              | 25 |
| Figure 19: Sample transmission measurement configuration.....              | 26 |
| Figure 20: Sphere storage configuration.....                               | 29 |
| Figure 21: Replacement bulb .....  | 30 |
| Figure 22: Lamp replacement .....  | 31 |
| Figure 23: Beam alignment patterns .....                                   | 32 |
| Figure 24: Lamp assembly components .....                                  | 32 |
| Figure 25: Sphere shown in the lamp alignment position.....                | 33 |
| Figure 26: Lamp beam alignment.....  | 35 |
| Figure 27: SVC DC-R/T Quick-start Usage Guide .....                        | 36 |
| Table 1: Alignment fastener list.....                                      | 34 |

### 3. DOCUMENT CONVENTIONS

This *User Guide* includes the following conventions:



The note icon is used to highlight important configuration information.



The caution icon is used to illustrate environments where an electrical shock hazard exists.



The heat icon indicates situations where hazardous temperatures exist.



The attention icon is used to highlight important configuration information where damage or system conflicts may occur.

### 4. RESERVED

## 5. UNPACKING THE SYSTEM

The system was thoroughly inspected before shipping and should be ready to operate after completing the set-up instructions. All products are packaged and shipped in reinforced shipping containers. Carefully check the components after unpacking for any damage that may have occurred during shipping.



If there is any such damage, file a claim immediately with the freight carrier and contact the reseller, Spectra Vista Corp, at +1 845-471-7007.

The system is shipped in a Pelican Storage case in one of two configurations, as shown below.

Carefully remove the system from the storage container and place it on a clean flat surface in preparation for assembly.



Figure 1: System in its shipment container (configuration #1)



Figure 2: System in its shipment container (configuration #2)

## 5.1. System Overview

This system is a rugged, field-ready R/T integrating sphere designed to measure reflectance and transmission of small ( $\frac{1}{2}$ " to  $\sim 2$ " diameter) samples. The system from Labsphere includes the sphere, port accessories, light source, connection interface port for a Spectra Vista Corporation (SVC) Spectroradiometer, a calibrated Spectralon standard and a sturdy carrying case.

The system consists of a 3" diameter Spectralon integrating sphere with four ports. The port on the bottom of the sphere connects directly to the SVC spectroradiometer. "Sample Holders" on Transmission and Reflectance ports are designed to hold small samples, such as leaves, in front of the port openings. The fourth port, the Primary Light Entrance Port, for is used for reflectance measurements. These ports are shown in Figure 3.

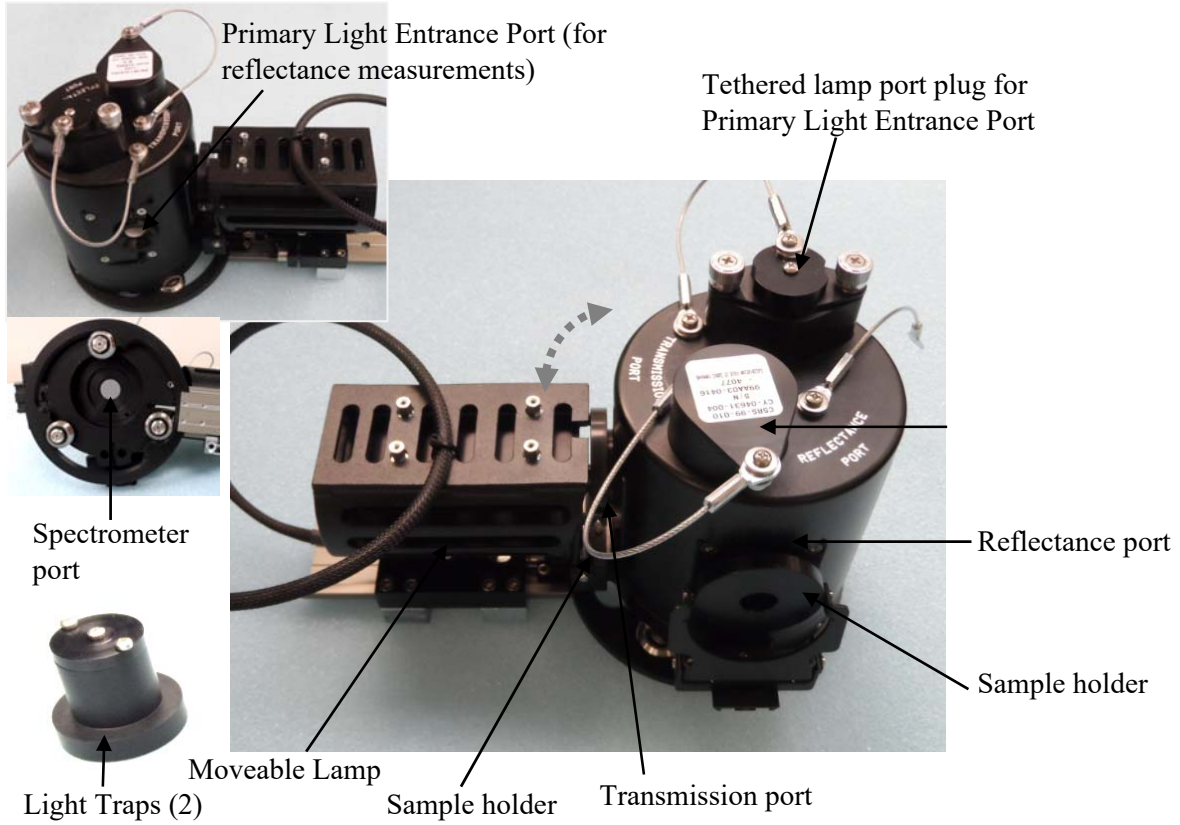

Figure 3: System view



## 6. INSTALLING THE SPHERE ON THE SVC SPECTRORADIOMETER

### 6.1. Attaching The Sphere

The SVC DC-R/T Sphere attaches to the spectroradiometer by means of a Sphere Support Bracket (shown below in blue) and three Instrument Support Legs (shown below in red).

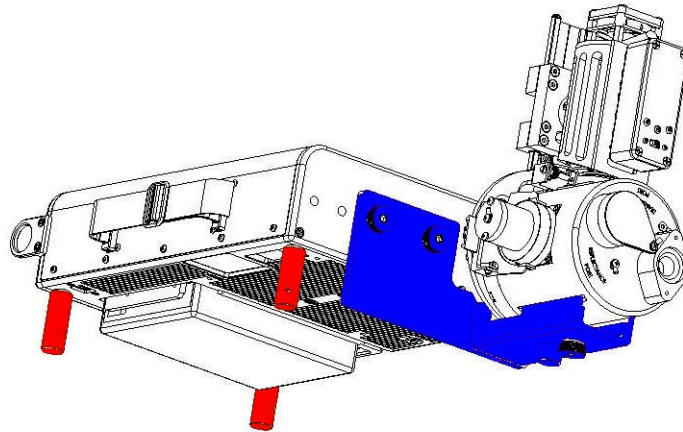

Figure 4: Sphere mounted on spectroradiometer

The Sphere Support Bracket includes three captured  $\frac{1}{4}$ -20 thumbscrews. Two thumbscrews fasten to the spectroradiometer's front panel, while a third thumbscrew fastens to the bottom of the Sphere Assembly.

Here are the disassembled parts, shown below:

Lens Cover over Sphere Exit Port Optics

Sphere Support Bracket

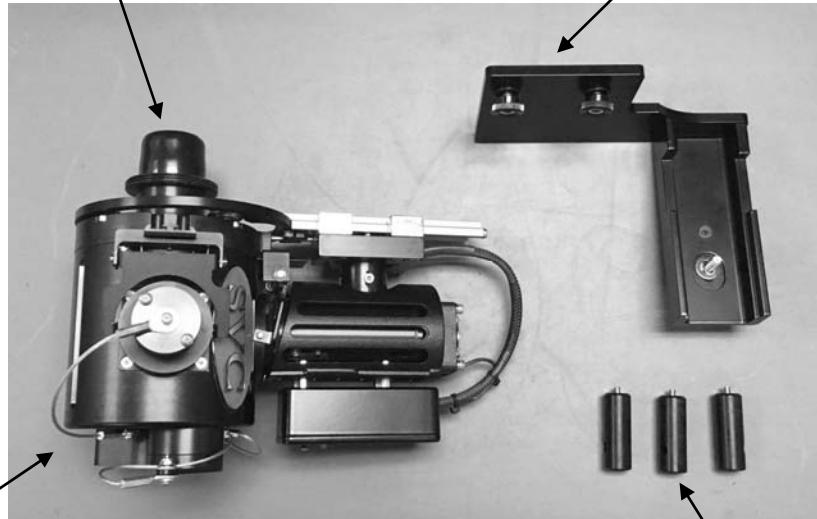

Sphere Assembly

Figure 5: SVC DC-R/T Sphere component parts

Instrument Support Legs (3)

First, remove and safely store any fore-optic that may already be installed on the spectroradiometer. The Sphere Assembly replaces the instrument's fore-optic.

Place the spectroradiometer upside down on a clean soft surface, and (if installed) remove the three #8-32 button head screws located in the three support leg positions. In place of the button head screws, install the three Instrument Support Legs as shown below:

Instrument Support Legs

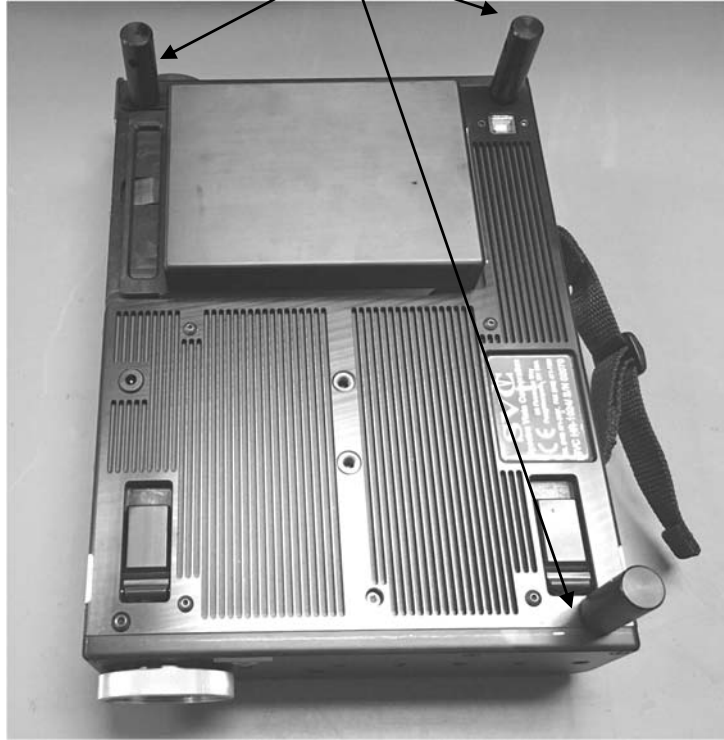

Figure 6: Installing the instrument support legs

**If not already assembled**, install the Sphere Support Bracket onto the bottom of the Sphere Assembly as shown below. Fit the support bracket flange into the two grooves located along the bottom of the Sphere assembly, and use the thumbscrew to attach the bracket. For now, leave the thumbscrew somewhat loose until later in the assembly process. If installed, remove the Lens Cover.

Lens Cover

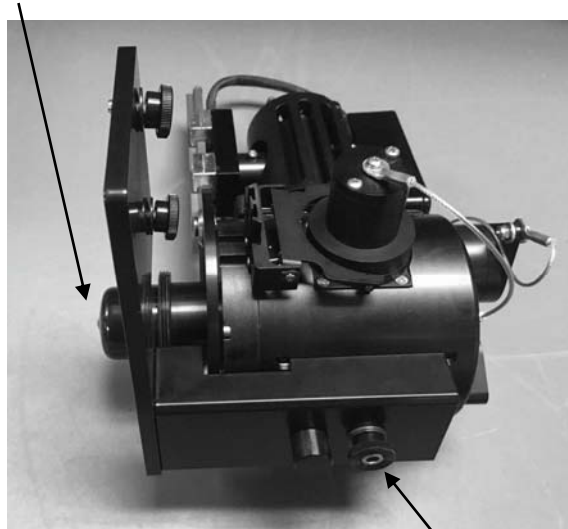

Figure 7: Support bracket installed on the sphere assembly

Thumbscrew

Turn the spectroradiometer over with the front plate facing you as shown below:

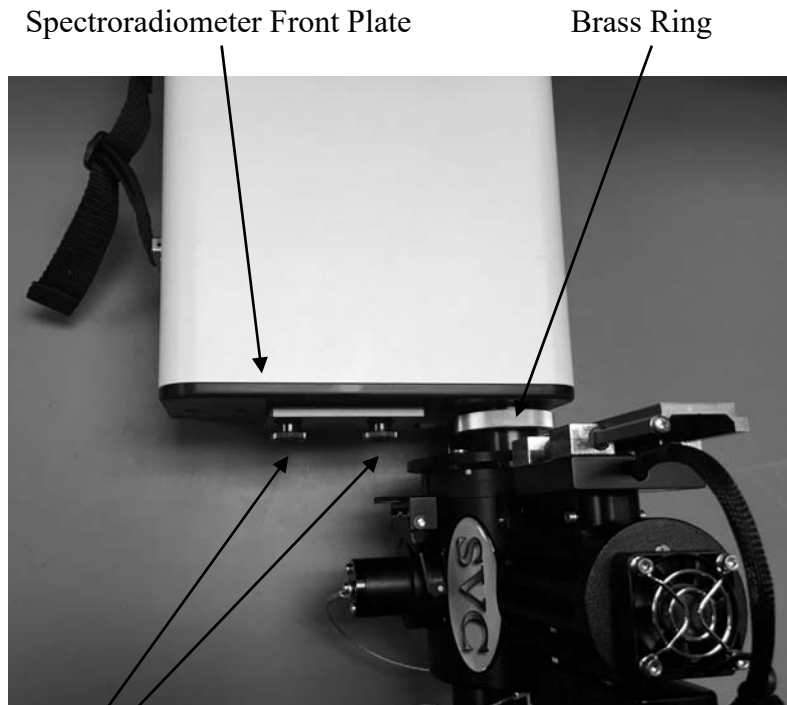

Figure 8: Preparing to attach the sphere to the spectroradiometer

Place the Sphere Assembly / Sphere Support Bracket against the front plate of the spectroradiometer as shown below.

Carefully insert the sphere exit port into the spectroradiometer's fore-optic receiver, and line up the bracket's two thumbscrews with the corresponding threaded holes on the front plate.

Slowly tighten the thumbscrews and the brass ring, alternating small turns between them, until the Sphere Support Bracket seats securely against the front plate. Note the correct direction to rotate the brass ring, per the note located on the front plate. Do not over-tighten the brass ring.



**Figure 9: Sphere attached to spectroradiometer**

Thumbscrews

At this point, check that all thumb screws are securely tightened.

## 6.2. Powering / Controlling The Sphere

The sphere is powered from AC mains voltage using an AC to DC converter (SVC P/N ASM1024-I-200), as shown below:



Figure 10: Main power supply

The AC to DC converter supplies 7.5 VDC at up to 6 amps of current via the Power Input Cable in order to power the sphere's lamp and fan assembly. The sphere's power module is shown below:

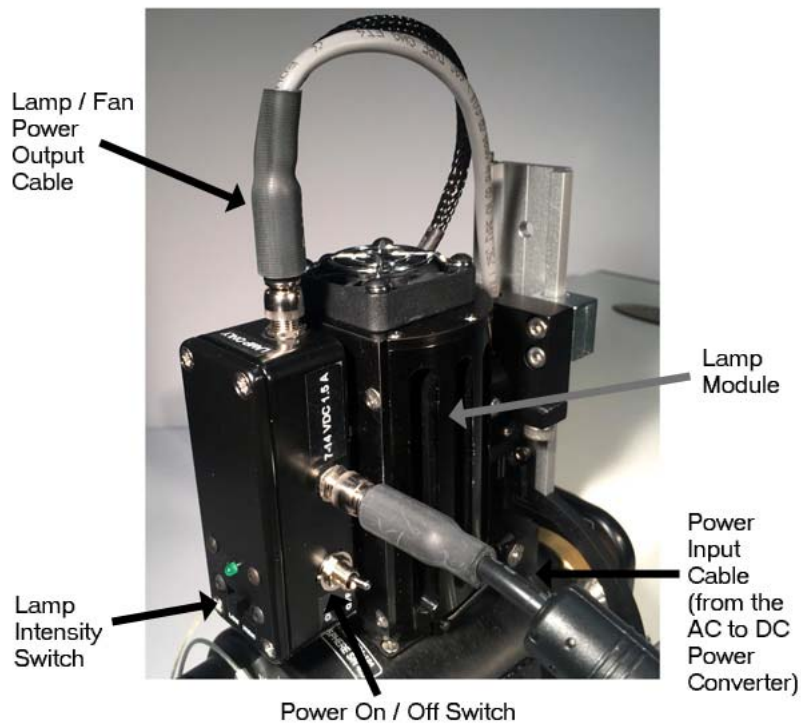
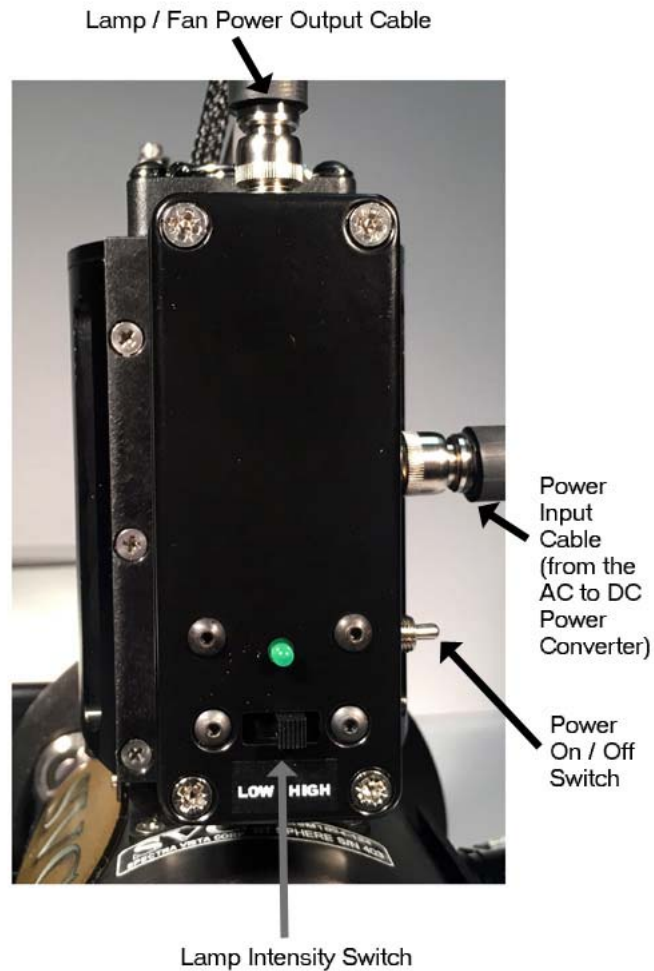

Figure 11: Sphere Power Module

The lamp intensity has two settings: HIGH (19 watts) and LOW (14.5 watts). The intensity is controlled via the Lamp Intensity slide switch, mounted on the cover of the sphere power module.

The sphere electrical controls and cabling are shown below:



**Figure 12: Sphere Intensity Controls**

## 7. LAMP PLACEMENT

Depending on the desired measurement (Reflectance or Transmission), the lamp needs to be placed in the correct position on the sphere.

When sample reflectance is measured, the lamp is placed at the sphere primary light entrance port. Details on the steps required for measuring reflectance are outlined in Section 8.

When percent transmission is measured, the lamp is placed directly behind the transmittance sample port. Details on the steps required for measuring transmittance are outlined in Section 9.

The following procedure outlines steps needed to move lamp from one position to another:



**Caution! The base of the lamp can get warm to the touch!  
Use the slotted heat-shield as a handle for moving the  
lamp.**



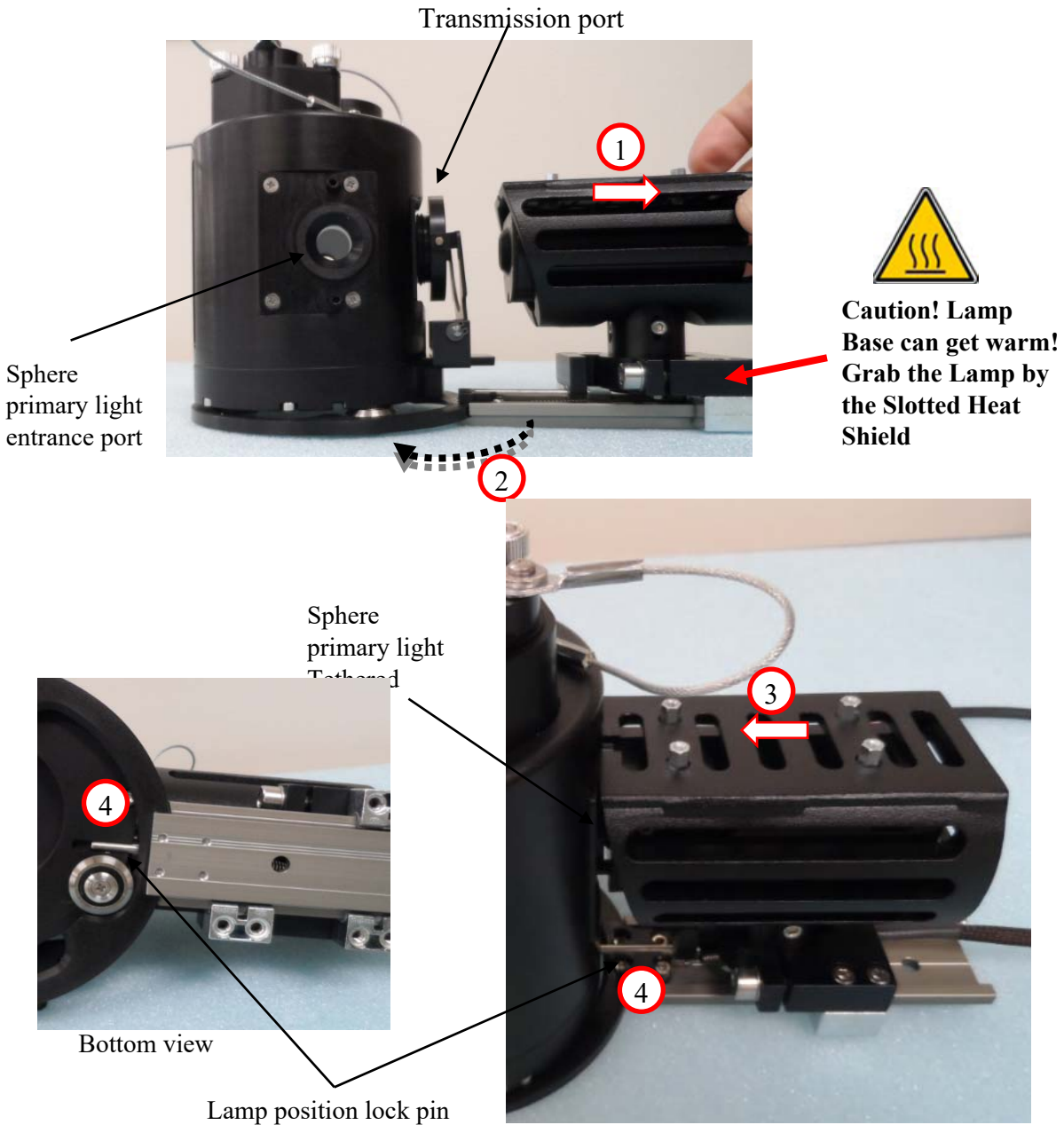

**Figure 13: Changing lamp position**

1. Disengage the lamp assembly by pulling it away from the sphere as shown in Figure 13.
2. Move lamp assembly until it is directly in front of primary light entrance port.
3. Release lamp assembly. Lamp will be placed in front of the light entrance port.
4. To ensure that the lamp is correctly placed and locked, gently try to move lamp assembly left and right. If it does not move, the locking pin is in place.

*Repeat this process in reverse to move lamp to the transmission port*

## 8. REFLECTANCE MEASUREMENTS



Measuring the spectral reflectance of a sample requires three different sphere configurations:

1. Stray Light measurement (open beam, “Dark Room” simulation)
2. Calibrated Spectralon standard reflectance measurement (a reference scan)
3. Sample reflectance measurement (a target scan)

The following sub-sections describe the sphere set up processes for the three measurement stages.

## 8.1. Stray Light Measurement

A stray light measurement characterizes the amount of light in the sphere that does not directly hit the sample in the reflectance port.

Always ensure the lamp is warmed up and stable (~5 minutes) before taking measurements.

1. Position the lamp in front of the sphere light primary entrance port. Make sure that lamp is securely locked in position. Use a thin piece of paper to ensure the beam under-fills and is centered in the reflectance port.
2. Place the calibrated Spectralon reflectance standard in the transmission port.
3. Place a light trap in the reflectance port.
4. Collect a spectral scan in this configuration. This data set will be referred to as  $S_{\text{Stray Light}}$ .

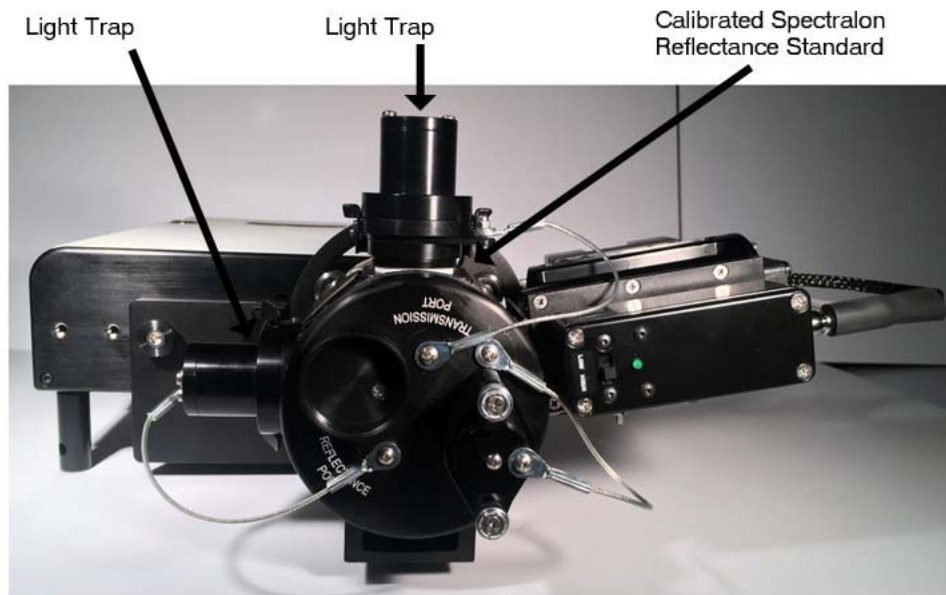

Figure 14: Stray light measurement configuration

## 8.2. Calibrated Standard Reflectance Measurement

To calibrate the spectral response of the sphere/spectroradiometer system to a NIST-traceable reflectance measurement, a calibrated Spectralon standard is included with the sphere. To measure the reflectance of this calibrated Spectralon standard, use the following procedure.

1. Position the lamp in front of the sphere light primary entrance port. Make sure that lamp is securely locked in position. Use a thin piece of paper to ensure the beam is centered on the reflectance port. The beam should be circular and not clip the edges of the exit port. If the beam needs alignment, refer to instructions in section 13.
2. Place each of light traps onto the backs of the sample holders as shown below in Figure 15. Twist clockwise to thread the light traps onto the holders.
3. Pull back on the light trap / sample holder assembly and place the tethered calibrated Spectralon reflectance standard between the sphere reflectance port and sample holder, as shown below in Figure 15. The spring-loaded arm holds the sample in place.
4. Place the sample (the leaf) in the sphere transmission port sample holder as shown below in Figure 15.
5. Collect a spectral scan in this configuration. This data set will be referred to as  $S_{Ref}$ .

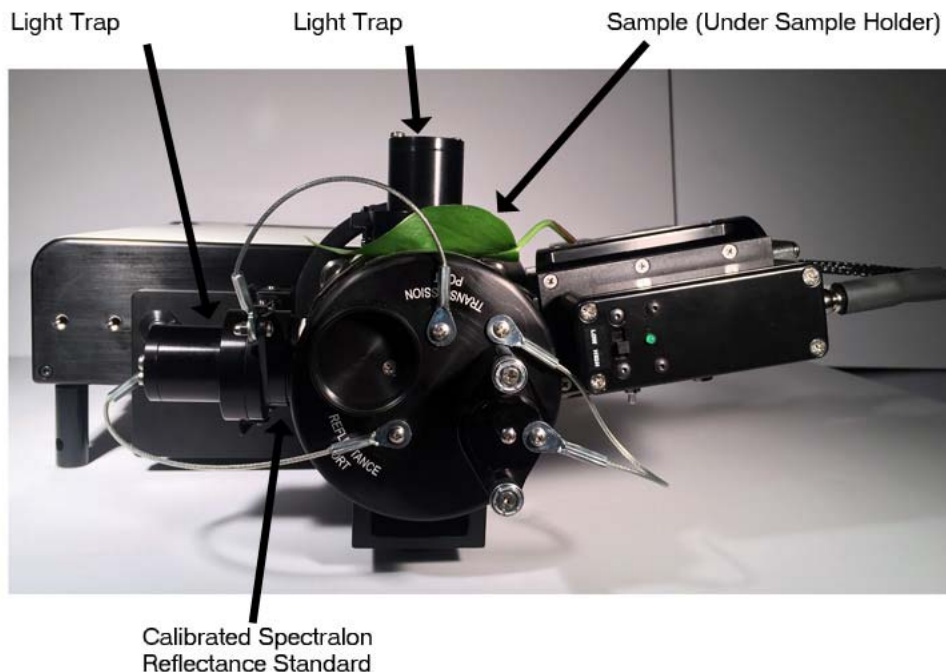

Figure 15: Calibrated standard reflectance measurement configuration

### 8.3. Sample Reflectance Measurement

The process of setting up this configuration is identical to that described above in section 8.2 above, except that the sample and calibrated Spectralon reflectance standard are swapped. This configuration is shown below in Figure 16.



It is very important to swap the sample with the Spectralon reference so that the optical throughput of the sphere for both measurements is maintained. Take care to line up the same section of the sample with the sample ports in both measurements.

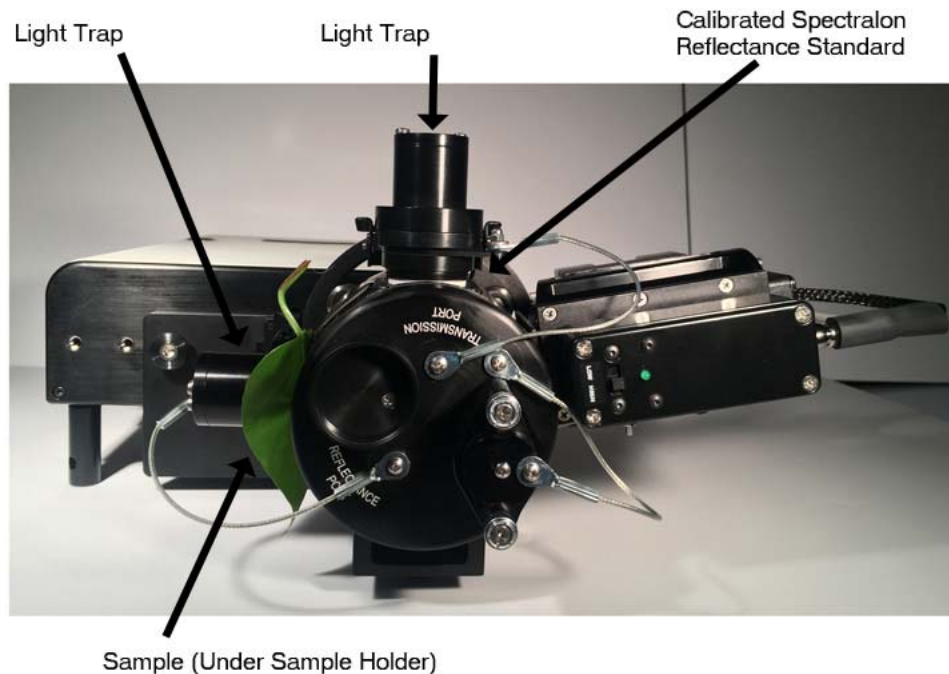

Figure 16: Sample reflectance measurement configuration

Collect a spectral scan in this configuration. This data set will be referred to as  $S_{\text{sample}}$ .

## 8.4. Calculating Sample Spectral Reflectance

To calculate the spectral reflectance of the sample, all three scans (stray light, calibrated reference and sample) are used. The equation for NIST-traceable spectral reflectance is:

$$R_{sample}(\lambda) = \left[ \frac{S_{sample}(\lambda) - S_{Stray\ Light}(\lambda)}{S_{Ref}(\lambda) - S_{Stray\ Light}(\lambda)} \right] \times R_{Ref}(\lambda)$$

$S_{sample}$  = counts recorded per wavelength range with the sample in the path of the beam

$S_{Stray\ Light}$  = counts recorded per wavelength range with light traps in the sample ports

$S_{Ref}$  = counts recorded per wavelength range with the Spectralon reference in the path of the beam

$R_{Ref}$  = is the calibrated spectral reflectance of the Spectralon reference

## 9. TRANSMITTANCE MEASUREMENTS



Measuring the spectral transmittance of a sample requires two different sphere configurations:

1. Sphere-only transmittance measurement (a reference scan)
2. Sample transmittance measurement (a target scan)

The two configurations are similar, except that the sample is moved from the reflectance port for the Sphere-only transmittance measurement to the transmission port for the Sample transmittance measurement.

The following sub-sections describe the sphere set up processes for the two measurement stages.

## 9.1. Sphere-Only Transmittance Measurement

A Sphere-only transmittance measurement characterizes the amount of light within the sphere, adjusted for the sample reflectance.

Always ensure the lamp is warmed up and stable (~5 minutes) before taking measurements.

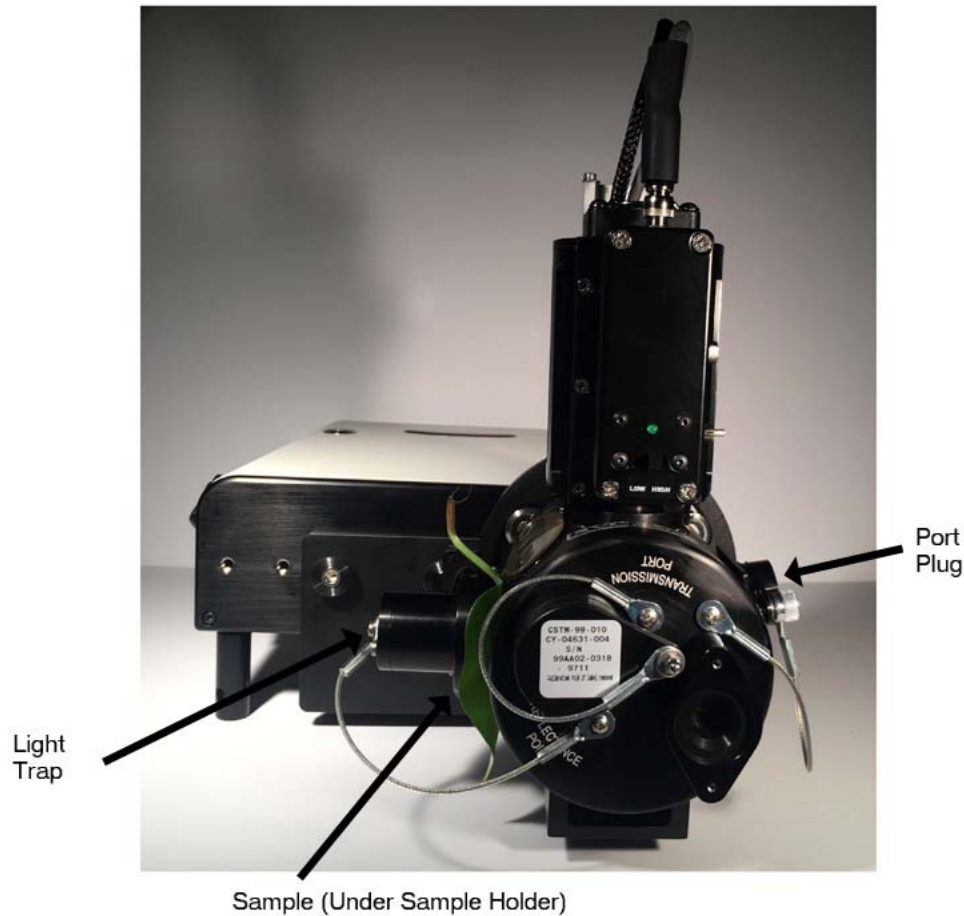

Figure 17: Sphere-only transmittance measurement configuration

1. Position the lamp in front of the sphere transmission port. Make sure that the lamp is securely in the locked position.
2. Loosen the two thumb-screws on top of tethered primary light port plug. Lift the port plug and place it in the primary light port, tighten its thumb-screws to securely mount it against the sphere, as shown in Figure 17.





The primary light port plug has curvature that matches the sphere and needs to be placed against the sphere surface correctly. Make sure the plug is oriented correctly before tightening the thumb screws. Note the alignment marks present on both the sphere port opening and plug storage area.

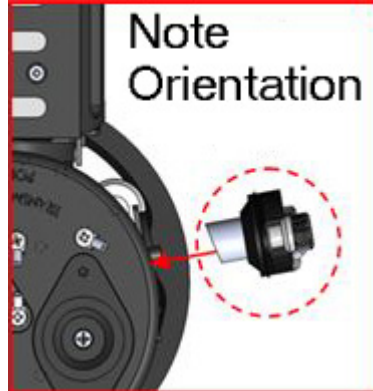

Figure 18: Port plug correct orientation

3. Place a light trap on the reflectance port sample holder.
4. Pull the reflectance port sample holder, and place the sample (i.e. a leaf) against the sphere reflectance port and release the sample holder, as shown in Figure 17.
5. Collect a spectral scan in this configuration. This data set will be referred to as  $T_{\text{reference}}$ .

## 9.2. Sample Transmittance Measurement

A sample transmittance measurement measures the amount of light that passes through the sample.

The process of setting up this configuration begins with the process in section 9.1 above. The sample is now removed from the reflectance port and placed in the transmission port. This configuration is shown below in Figure 19.



Figure 19: Sample transmission measurement configuration

1. Pull the reflectance port sample holder and remove the sample from the sphere reflectance port, carefully noting its orientation with respect to the port. It is not necessary to remove the light trap.
2. Gently pull the lamp / sample holder away from sphere, and place the sample in front of the transmission port as shown in Figure 19. Release the lamp / sample holder and move the lamp back to its locked position.



Take care to line up the same side and section of the sample exposed to the sphere reflectance port when placing it in front of the transmission port.

3. Collect a spectral scan with the sample in place. This data set will be referred to as  $T_{\text{sample}}$ .



Acquire the spectral scan as quickly as possible and remove the sample when complete in order to minimize the effect of the light source on the sample.

### 9.3. Calculating Sample Spectral Transmittance

To calculate transmittance, use the following formula:

$$\text{Sample Transmittance } (\lambda) = \frac{T_{\text{sample}}(\lambda)}{T_{\text{reference}}(\lambda)}$$

$T_{\text{sample}}$  = counts recorded per wavelength range with the sample between the lamp and the sphere

$T_{\text{reference}}$  = counts recorded per wavelength range with no sample between the lamp and the sphere.

## 10. SYSTEM CONFIGURATION WHEN NOT IN USE

To prepare the system for storage in its case, follow the step below. It is important to block open ports with the lamp, light trap and port covers (if supplied) as shown in Figure 20. This will keep sphere clear of air borne containments.

1. Disconnect the power cable.
2. If necessary, remove the sphere / bracket assembly from the spectrometer, reversing the steps found in section 6.1. Note that some systems ship with enough storage space within the Pelican case to allow the bracket to remain attached to the sphere during storage.
3. Place the lamp in front of the transmission port.
4. Remove samples from the reflectance port.
5. If supplied, place a port cover over both of the sample ports.
6. Cover the instrument port with a lens cap.

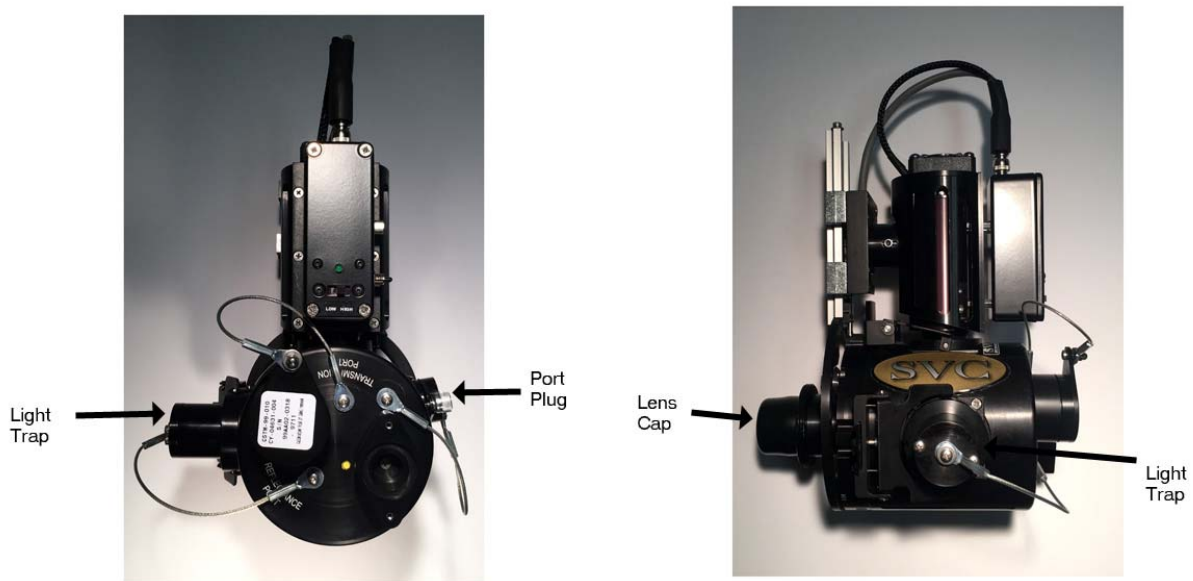

Figure 20: Sphere storage configuration

The sphere can now be placed in its storage case (as shown in Figure 1 or Figure 2).

## 11. LAMP BULB REPLACEMENT

The lamp uses a 20W 6V Halogen Display/Optics bulb as shown in Figure 21. The average life of this bulb is about 100 hours. Depending on usage of the lamp, you need to replace bulb frequently.



Figure 21: Replacement bulb



After replacing the bulb, the beam must be aligned as described in section 13.

The lamp replacement steps are described in Figure 22 below.

**Step 1:**

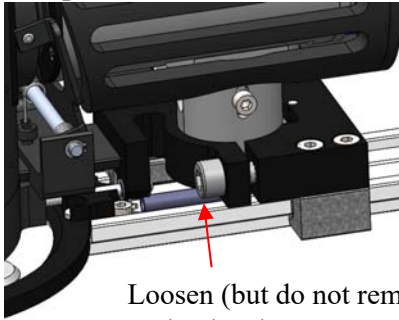

Loosen (but do not remove) clamp socket head cap screw (5mm hex)

**Step 2:**

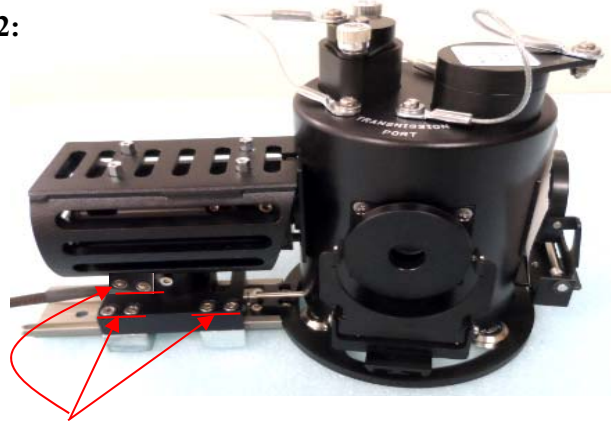

Remove 6x socket head cap screws (3mm hex)

**Step 3:**

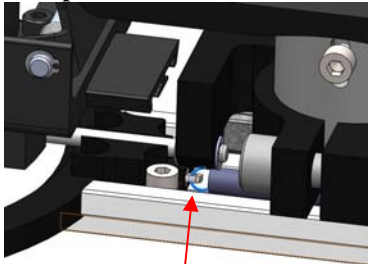

Unhook spring from rotating base to free the lamp assembly

**Step 4:**

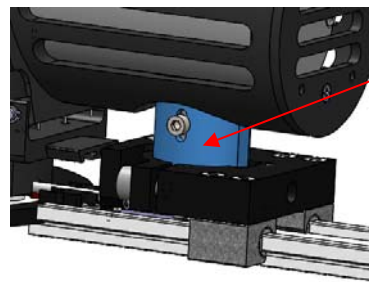

Remove lamp base from lower clamp. Take care not to tug on the lamp leads

**Step 5:**

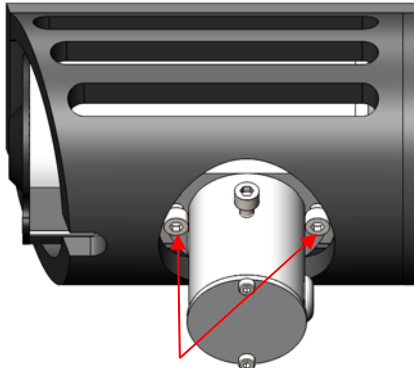

Remove 2x socket head cap screws (3mm hex) to lower lamp from housing

**Step 6:**

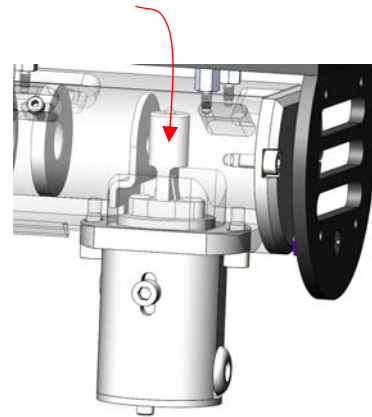

Lamp installation is the reverse of removal.

Be sure to re-align the beam after replacing the bulb.

Figure 22: Lamp replacement

## 12. LAMP BEAM ALIGNMENT TEST

It is recommended to check beam alignment every time before measuring sample reflectance. Also, the beam must be re-aligned after replacing the bulb.

The following process describes how to check the lamp beam alignment.

1. Move the lamp in front of the primary light entrance port.
2. Place a post-it note or a small piece of mylar or paper in front of the reflectance port.
3. Place the calibrated Spectralon reflectance standard in the Transmission port.
4. Turn on the lamp.
5. Check the light beam shining on the white paper, in reflectance port, is under filled and at the center of the port. An ideal beam should be centered in the port, and be circular with sharp edges. If not, you must align the lamp beam as describe in section 13.

Figure 23: Beam alignment patterns



Good beam alignment



Beam needs alignment  
(Clipping Entrance Port)



Beam needs alignment  
(Clipping Exit Port)

Figure 24: Lamp assembly components

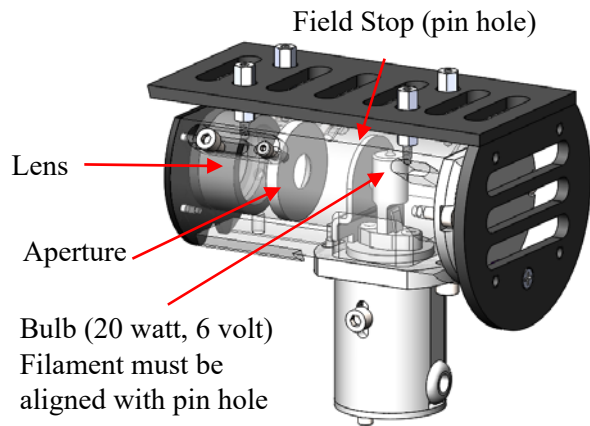



### 13. ALIGNING LAMP LIGHT BEAM

To align the beam, first place the sphere assembly with its instrument mount on a padded table top. Orient the assembly as shown in Figure 25 below. In this position, the pairs of fasteners that control the collimating Lens position, Aperture position, and Filament centering (fastener callouts in Figure 24: Lamp assembly components Figure 26) are more easily accessible in pairs.

Remove the reflectance port sample holder; this is held in place with a single fastener at its base. Loosen this fastener and slide the sample holder off of the assembly.

Tape a small piece of mylar or thin paper over the reflectance port opening. This will show the beam alignment within the reflectance port opening as adjustments are made.

The results of the steps above are shown in Figure 25 below:



Figure 25: Sphere shown in the lamp alignment position

### Alignment Procedure Tips:

Study the internal components of the lamp assembly to understand what is being done. Major components of the lamp assembly are shown in detail in Figure 24

Use the lamp’s “HI” power setting during alignment.

Perform the alignment in a partially darkened room. This will allow the aligner to see the light spot on the mylar/paper more clearly.

Before beginning optical alignment, ensure that the lamp assembly is mechanically aligned and seated correctly in the primary (reflectance) position port. The lamp assembly should slide easily and completely into the light port. It should not be necessary to push the assembly into the port – it should be pulled into place by spring tension only. If this is not the case, loosen fastener #5 “Horizontal and Vertical Beam Positioning” and adjust the lamp assembly’s height and pitch.

Do not over-tighten optical alignment fasteners. The fasteners should only be “snug” tight, do not apply excessive force or the fasteners may strip.

Avoid over-focusing the lamp. During alignment, when the collimating Lens is in a certain position, you may see a perfectly focused image of the lamp filament at the reflectance port. If so, it is best to de-focus the image a bit to blur this image and make a more even illuminated field.

Use a pair of hex wrenches to slide the Lens and Aperture within the lamp assembly. These components are close-fit within the lamp assembly tube’s inner diameter. Once their paired fasteners are loosened, it is best to use two hex wrenches to slide the components fore/aft within the lamp assembly tube, one wrench on each side, pushing gently to move the Lens/Aperture as necessary.

### Alignment Fastener List

If it is necessary to replace a missing alignment fastener, use the following table. Please refer to the fastener callouts on Figure 26 to identify each. These fasteners are all of type stainless steel (SS) Socket Head Cap Screws (SHCS). **Do not substitute, use only the fasteners listed or damage may occur.**

| Fastener Callout #                              | For Sphere S/N ≤ 408 | For Sphere S/N ≥ 409 |
|---|----------------------|----------------------|
| 1   | M3 x 6.7* mm         | M3 x 8 mm            |
| 2   | M2 x 6 mm            | M2 x 8 mm            |
| 3   | M3 x 6 mm            | M3 x 6 mm            |
| 4   | M3 x 6 mm            | M3 x 6 mm            |
| 5   | M6 x 16 mm           | M6 x 16 mm           |
| *Contact SVC for this specialized fastener size |                      |                      |

Table 1: Alignment fastener list

Adjusting sharpness of spot edges

2.5 mm Hex – one on each side  
Slide to adjust beam focal point

Adjusting spot size

1.5 mm Hex – one on each side  
Slide to adjust spot size

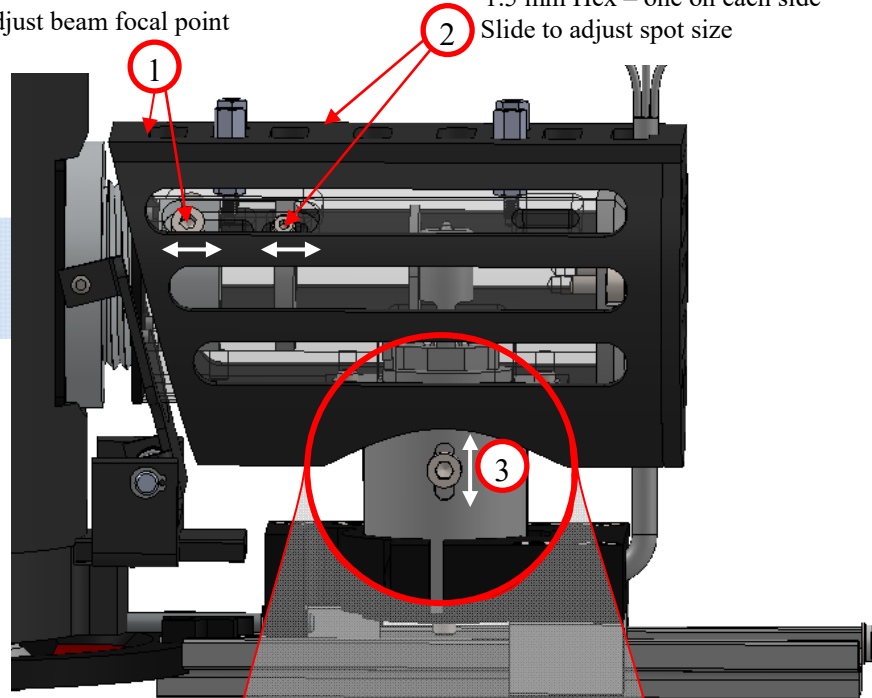

Adjust Field Stop (pin hole)

2.5 mm Hex  
Slide to align pin hole  
to adjust beam height

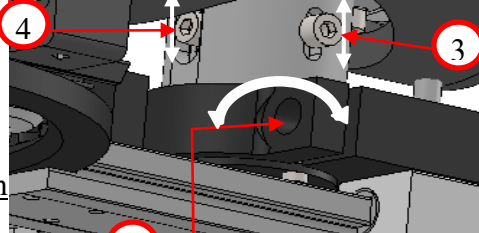

Horizontal and vertical beam positioning

5 mm Hex  
Loosen clamp to rotate the lamp to center the beam (left and right) in the primary light port



Centering filament optical path

2.5 mm Hex one on each side  
Slide to adjust Filament Height to the center of the optical path

*Repeat steps 1 through 4, in any order, until you have a perfect beam size, shape and sharpness.*

After alignment, the beam should under-fill and be centered on the reflectance port.

Beam size and shape after factory alignment setting is shown in this picture.

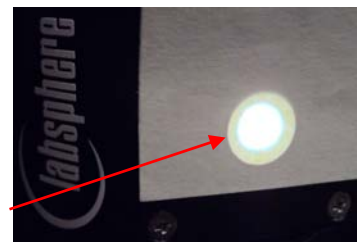

Figure 26: Lamp beam alignment

## 14. APPENDIX A: REFLECTANCE / TRANSMISSION QUICKSTART

The following diagram shows schematically the correct position of light source and sample material for each type of R/T measurements.

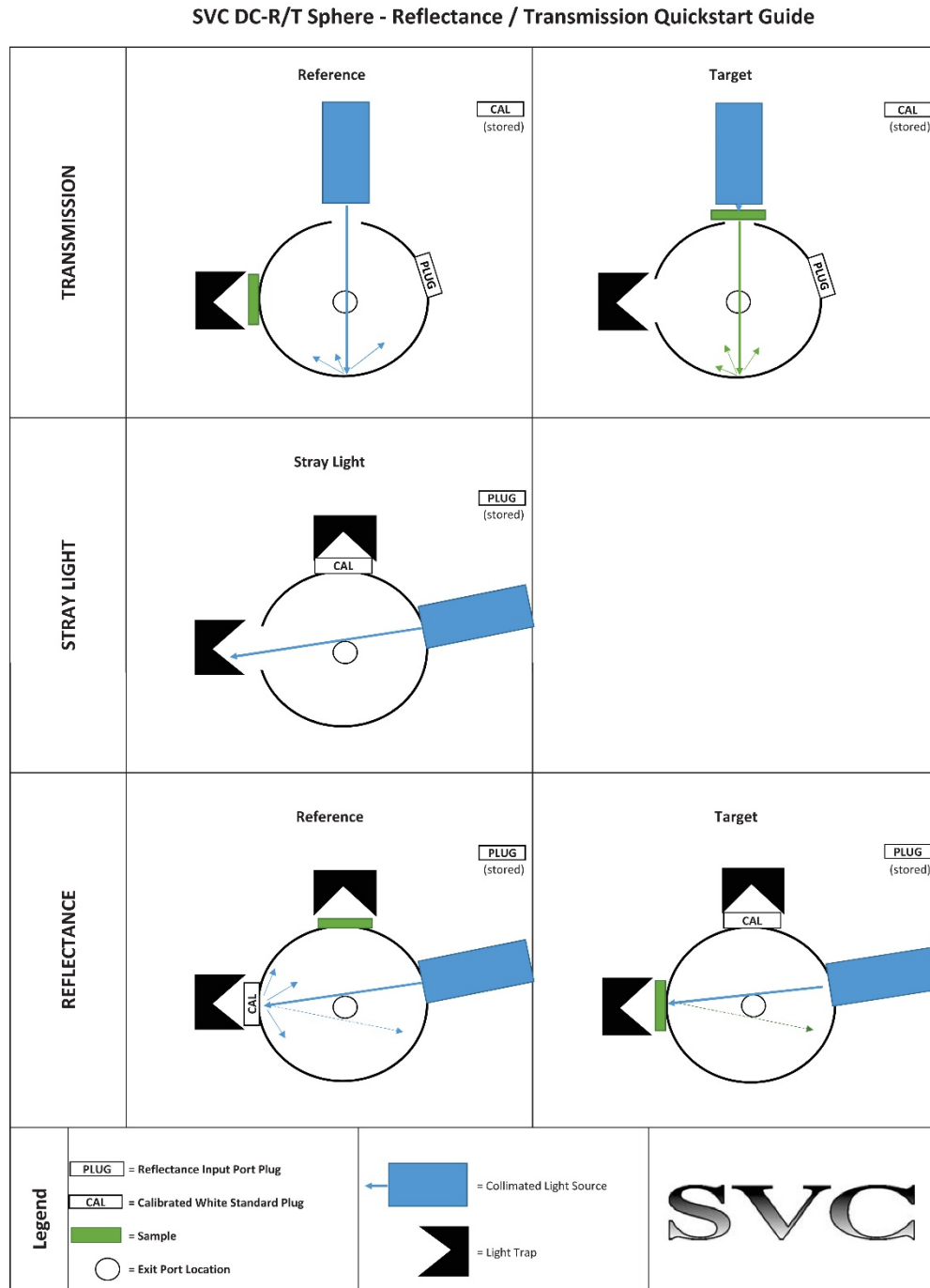

Figure 27: SVC DC-R/T Quick-start Usage Guide